

Modular Cooking Range Line thermaline 80 - 7 lt Well Freestanding Electric Deep Fat Fryer, 1 Side H=700

ITEM # _____

MODEL # _____

NAME # _____

SIS # _____

AIA # _____



588209 (MAFAEADDAO) 7lt electric Deep Fat Fryer, one-side operated

Short Form Specification

Item No.

Unit constructed according to DIN 18860_2 with 20 mm drop nose top and 70 mm recessed plinth. Internal frame for heavy duty sturdiness in stainless steel. 2 mm top in 1.4301 (AISI 304). Flat surface construction, easily cleanable. THERMODUL connection system enables seamless worktop when units are connected and avoids soil penetrating. Appliance designed to deep fry meat, fish and vegetables (french fries). Deep drawn V-shaped well with external heating elements to facilitate cleaning operations. Indirect oil heating system and uniform heat distribution for extended oil life. Electronic sensor for precise oil temperature control. Reduced power setting to melt solid fat. Oil can be easily drained via a ball-valve. All-round basin raised edges to protect against soil infiltration. Large overflow stamped area around the well. Overheat protection switches off the supply in case of overheating. Standby function saves energy and quickly recovers maximum power. Metal knobs with embedded hygienic silicon "soft" grip enable easier handling and cleaning. IPX5 water resistant certification.
 Configuration: Freestanding, one-side operated.

Main Features

- All major components may be easily accessed from the front.
- THERMODUL connection system creates a seamless work top when units are connected to each other thus avoiding soil penetrating vital components and facilitating the removal of units in case of replacement or service.
- Metal knobs with embedded hygienic "soft-touch" grip for easier handling and cleaning. The special design of the controls prevents infiltration of liquids or soil into vital components.
- Overheat protection: the temperature sensor switches off the supply in case of overheating.
- Large visible digital display manufactured in tempered glass to resist heat and chemicals, showing temperatures or power settings. The display also shows on/off status of the appliance and on/off status of the heating elements.
- Raised edge all around the well to protect from infiltration of dirt from worktop.
- Deep drawn V-Shaped well.
- Large overflow stamped area, located around the well.
- External heating elements allow to easily clean the well.
- Indirect oil heating system and uniform heat distribution to guarantee extended oil life.
- Reduced power setting to melt solid fat.
- Oil level mark for MAX/MIN filling.
- Designed for deep fat frying of meat, fish, specialities and vegetable (french fries, chips).
- Oil can be drained off via a ball-valve with a lock to prevent unintentional opening. When opened, the ball valve provides a full cross-section opening to easily clean the drainage system.
- Electronic sensor for precise oil temperature control.

Construction

- 2 mm top in 1.4301 (AISI 304).
- Unit constructed according to DIN 18860_2 with 20 mm drop nose top and 70 mm recessed plinth.
- Flat surface construction with minimal hidden areas to easily clean all surfaces
- IPX5 water resistance certification.
- Internal frame for heavy duty sturdiness in stainless steel.

Sustainability

- Standby function for energy saving and fast



APPROVAL: _____

recovery of maximum power.

- This model is compliant with Swiss Energy Efficiency Ordinance (730.02).

Included Accessories

- 1 of Filter for 2x5 and 7lt deep fat fryer oil collection basin PNC 913154

Optional Accessories

- Connecting rail kit, 800mm PNC 912500
- Stainless steel side panel, 800x700mm, freestanding PNC 912509
- Stainless steel front kicking strip, 400mm width PNC 912630
- Stainless steel side kicking strip left and right, freestanding, 800mm width PNC 912655
- Stainless steel side kicking strip left and right, back-to-back, 1610mm width PNC 912661
- Stainless steel plinth, freestanding, 400mm width PNC 912859
- Connecting rail kit: modular 80 (on the left) to ProThermetic tilting (on the right), ProThermetic stationary (on the left) to ProThermetic (on the right) PNC 912971
- Connecting rail kit: modular 80 (on the right) to ProThermetic tilting (on the left), ProThermetic stationary (on the right) to ProThermetic (on the left) PNC 912972
- Endrail kit, flush-fitting, left PNC 913109
- Endrail kit, flush-fitting, right PNC 913110
- Endrail kit (12.5mm) for thermaline 80 units, left PNC 913200
- Endrail kit (12.5mm) for thermaline 80 units, right PNC 913201
- Stainless steel side panel, left, H=700 PNC 913214
- Stainless steel side panel, right, H=700 PNC 913215
- Insert profile D=800mm PNC 913230
- Energy optimizer kit 14A - factory fitted PNC 913244
- Endrail kit, (12.5mm), for back-to-back installation, left PNC 913249
- Endrail kit, (12.5mm), for back-to-back installation, right PNC 913250
- Endrail kit, flush-fitting, for back-to-back installation, left PNC 913253
- Endrail kit, flush-fitting, for back-to-back installation, right PNC 913254
- Side reinforced panel only in combination with side shelf, for freestanding units PNC 913258
- Side reinforced panel only in combination with side shelf, for back-to-back installations, left PNC 913271
- Side reinforced panel only in combination with side shelf, for back-to-back installation, right PNC 913272
- Filter W=400mm PNC 913663

- Stainless steel dividing panel, 800x700mm, (it should only be used between Electrolux Professional thermaline Modular 80 and thermaline C80) PNC 913668
- Stainless steel side panel, 800x700mm, flush-fitting (it should only be used against the wall, against a niche and in between Electrolux Professional thermaline and ProThermetic appliances and external appliances - provided that these have at least the same dimensions) PNC 913684

Front

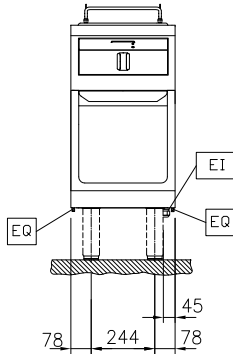

Side

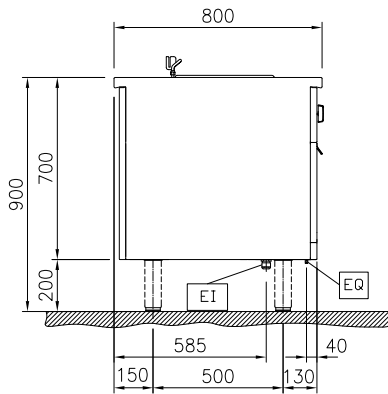

EI = Electrical inlet (power)
 EQ = Equipotential screw

Top

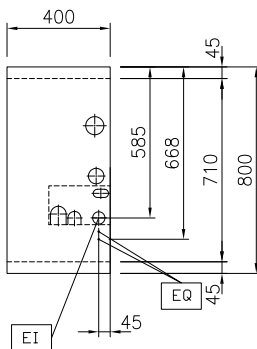

Electric

Supply voltage: 400 V/3N ph/50/60 Hz
 Total Watts: 5.4 kW

Key Information:

Number of wells: 1
 Usable well dimensions (width): 240 mm
 Usable well dimensions (height): 135 mm
 Usable well dimensions (depth): 380 mm
 Well capacity: 6 It MIN; 7 It MAX
 Thermostat Range: 100 °C MIN; 180 °C MAX
 External dimensions, Width: 400 mm
 External dimensions, Depth: 800 mm
 External dimensions, Height: 700 mm
 Net weight: 70 kg
 Configuration: On Base; One-Side Operated

Sustainability

Current consumption: 7.8 Amps

Included Accessories

- 1 of Filter for 2x5 and 7lt deep fat fryer oil collection basin PNC 913154

Optional Accessories

- Connecting rail kit, 800mm PNC 912500
- Stainless steel side panel, 800x700mm, freestanding PNC 912509
- Stainless steel front kicking strip, 400mm width PNC 912630
- Stainless steel side kicking strip left and right, freestanding, 800mm width PNC 912655
- Stainless steel side kicking strip left and right, back-to-back, 1610mm width PNC 912661
- Stainless steel plinth, freestanding, 400mm width PNC 912859
- Connecting rail kit: modular 80 (on the left) to ProThermetic tilting (on the right), ProThermetic stationary (on the left) to ProThermetic (on the right) PNC 912971
- Connecting rail kit: modular 80 (on the right) to ProThermetic tilting (on the left), ProThermetic stationary (on the right) to ProThermetic (on the left) PNC 912972
- Endrail kit, flush-fitting, left PNC 913109
- Endrail kit, flush-fitting, right PNC 913110
- Endrail kit (12.5mm) for thermaline 80 units, left PNC 913200
- Endrail kit (12.5mm) for thermaline 80 units, right PNC 913201
- Stainless steel side panel, left, H=700 PNC 913214
- Stainless steel side panel, right, H=700 PNC 913215
- Insert profile D=800mm PNC 913230
- Energy optimizer kit 14A - factory fitted PNC 913244
- Endrail kit, (12.5mm), for back-to-back installation, left PNC 913249
- Endrail kit, (12.5mm), for back-to-back installation, right PNC 913250
- Endrail kit, flush-fitting, for back-to-back installation, left PNC 913253
- Endrail kit, flush-fitting, for back-to-back installation, right PNC 913254
- Side reinforced panel only in combination with side shelf, for freestanding units PNC 913258
- Side reinforced panel only in combination with side shelf, for back-to-back installations, left PNC 913271
- Side reinforced panel only in combination with side shelf, for back-to-back installation, right PNC 913272

- Filter W=400mm PNC 913663
- Stainless steel dividing panel, 800x700mm, (it should only be used between Electrolux Professional thermaline Modular 80 and thermaline C80) PNC 913668
- Stainless steel side panel, 800x700mm, flush-fitting (it should only be used against the wall, against a niche and in between Electrolux Professional thermaline and ProThermetic appliances and external appliances - provided that these have at least the same dimensions) PNC 913684